

USING PROJECTS TO TEACH INDIANA HISTORY

By Patricia Johnson

GRADE LEVEL: Elementary

Prepared in partial fulfillment of requirements for
"INDIANA AND THE NEW NATION, 1776-1876"
a project of the Historic Southern Indiana Project
of the University of Southern Indiana
8600 University Boulevard
Evansville, Indiana 47712
(812) 465-7014

FUNDED BY THE NATIONAL ENDOWMENT FOR THE HUMANITIES

THIS DOCUMENT MAY NOT BE DUPLICATED WITHOUT WRITTEN PERMISSION FROM
THE UNIVERSITY OF SOUTHERN INDIANA

Using projects to teach Indiana History

A Lesson Plan for Using Projects to Make History Fun

Prepared by Patricia C. Johnson

Indiana and The New Nation A USI and NEH Project

My Indiana History class is divided into six units, making a timeline. Each unit covers six weeks of the school year. The units are Indians in Indiana (this includes pre-historic as well as historic), Pioneers Statehood, Indiana and the Civil War, the Invention period and Indiana Today. With each unit I do a series of crafts designed to go along with that unit. I set aside one day a week as a project day. Usually Friday, is my project day. This gives projects two days to set before they have to be moved.

Projects for the Indian Period include clay pottery, beadwork, tom-toms, canoes, tom-a-hawks, tee-pees, picture writing, Indian Dancing, etc. I buy a 25 lb. block of red clay from a ceramic supply house (this usually last two years and cost less than \$10.00). I show the students how to use the coil method, the pinch-pot method and the slab method. They inturn design their own project. Some of the more daring have begun making peace pipes.

The beadwork, I learned working at Little Hoosier Camp. I have wooden looms which I made, crochet cotton and regular sewing thread. I use regular Indian seed beads, which can be purchased at craft shops or through school art deparatment catalogues. The students use a piece of graft paper and work out their designs before starting with the beads. Their finished project is 10 beads wide and twice through their design. I then take the finished project sew it onto a piece of grosgrain ribbon. The students decide if they want a headband, armband or neck band.

The Tom-toms and canoes are made out of old innertubes, which you can pick up free at a tire store.(Be sure to hose them down good or let them hang out in the rain.) Cut the canoe shape (double-do not cut accross the bottom) Let the students paint designs on them and then glue the ends together. The Tom-toms are made by cutting two circles of the innertube and punching holes around the edge and lacing to a coffee can with both top and bottom removed. I use yarn as the lacing. Tee-Pees are paper constructed and the Indian picture writing is done on brown grocery bags cut into animal skin

shapes. The writing is done in a circular fashion beginning at the middle and working your way out. Indian Dancing is taught by using books I have picked up at various places. The tomahawks are made using roll ends of material used in making cast for broken bones. The plaster craft is wetted and placed around a form cut from a folder, which has been secured around a handle made from a tree limb, broom handle or dow rod. The finished project is then painted black and decorated with feathers and painted designs on the handle.

The Pioneer projects include log cabins, made from twigs, craft sticks, tooth picks, matches etc. Covered wagons, quilts, samplers, drying apples stringing green beans to dry, rag dolls, etc.,

The covered wagons are made from cheese boxes, old sheeting and wires bent to form the framework. The wheels are made from circles cut from plywood. The quilts are desk sized, and made from scraps of material brought in by the students. They use squares about three to four inches. After sewing the squares together, they layer them with quilting fiber and a backing sheet and quilt them with yarn knots at the center and each corner of the squares. The samplers are cross stitch designs, again worked on graft paper. I let the students choose what they want to write on them, stressing that a sampler was usually a family record, finished as a way of showing the many stitches a young lady could do, thus making her more valuable as a wife.

The Statehood projects include the symbols of statehood, the Indiana flag, the state seal, and paper construction of the first capitol building at Corydon, along with other buildings to construct a town similar to what Corydon might have looked like.

The Civil War projects include constructing both a union and a confederate campsite. I use paper construction in this project. I use horses, wagons, cannons, soldiers, and puppets. We also do a plantation scene with slaves, cotton fields and the big plantation house.

The period of time when inventions were the norm, I have patterns for an old studebaker car, Elwood Haynes car, an innerurban, etc. These are also

Capital at
Corydon

No 17

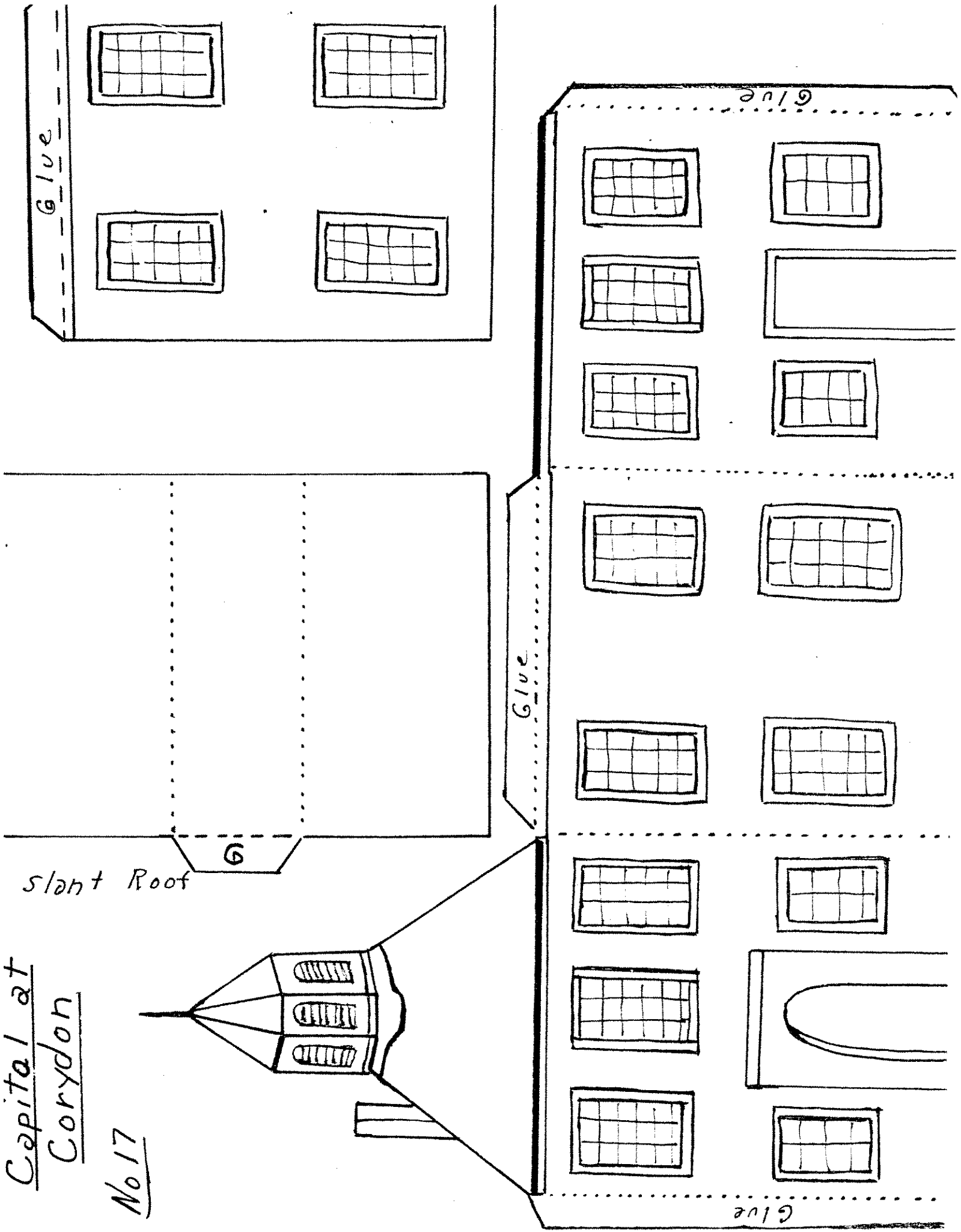

Capital at
Corydon

No 17

Slant Roof

6

Glue

Glue

Glue

Glue

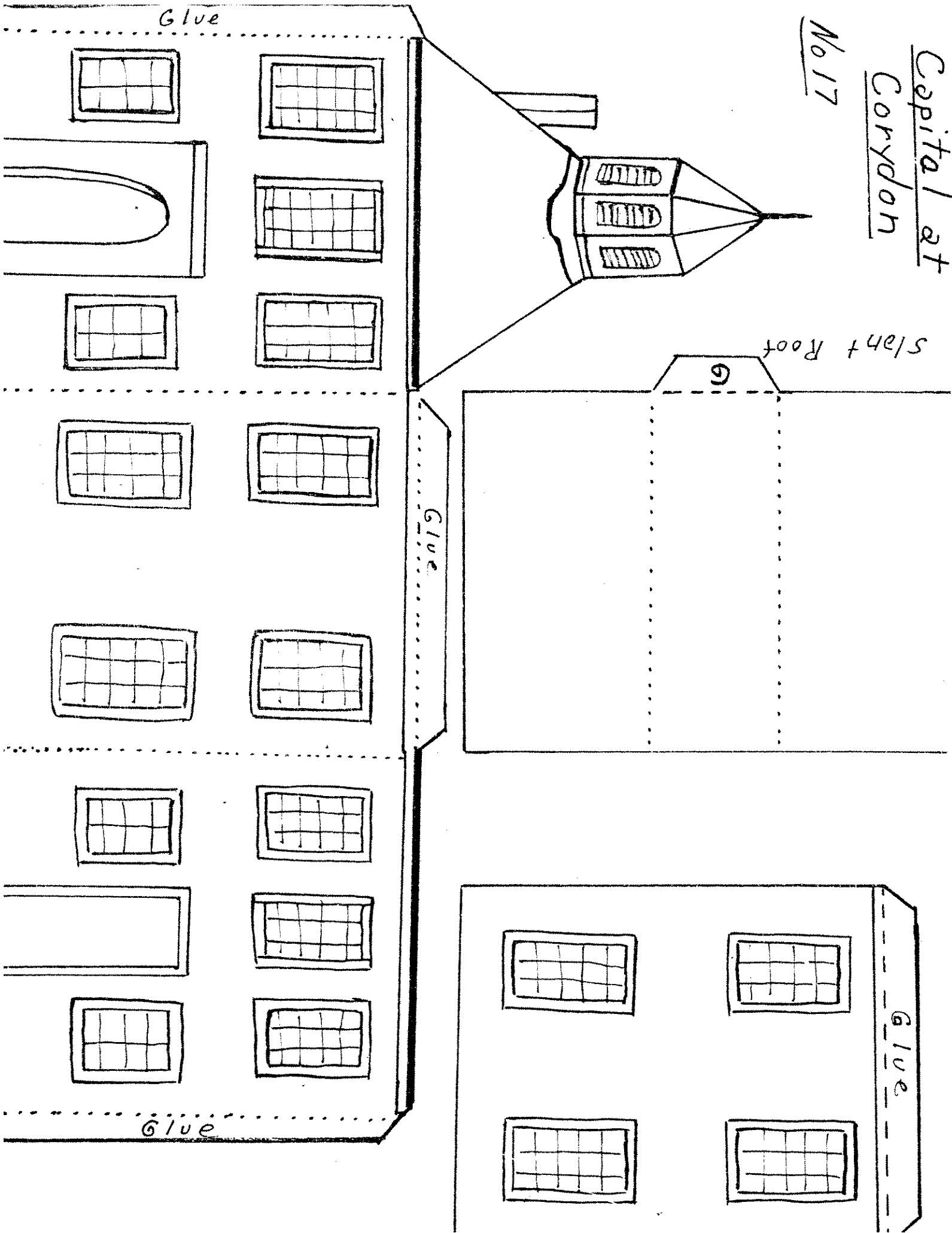

No. 13 Cover for
Wagon

You may
want to
make oxen
from the
next
activity

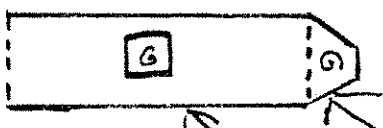
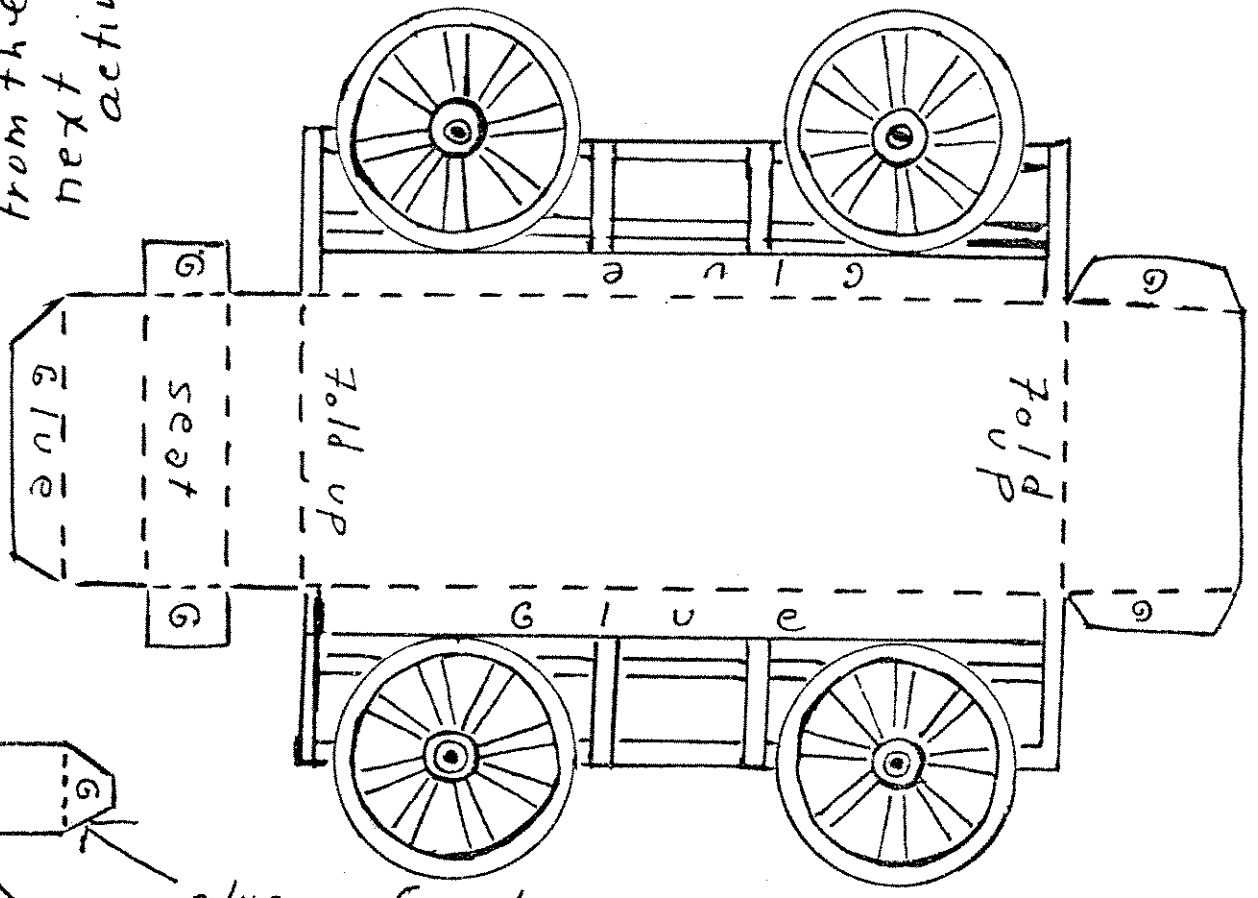

glue

glue in front-
bottom of wagon

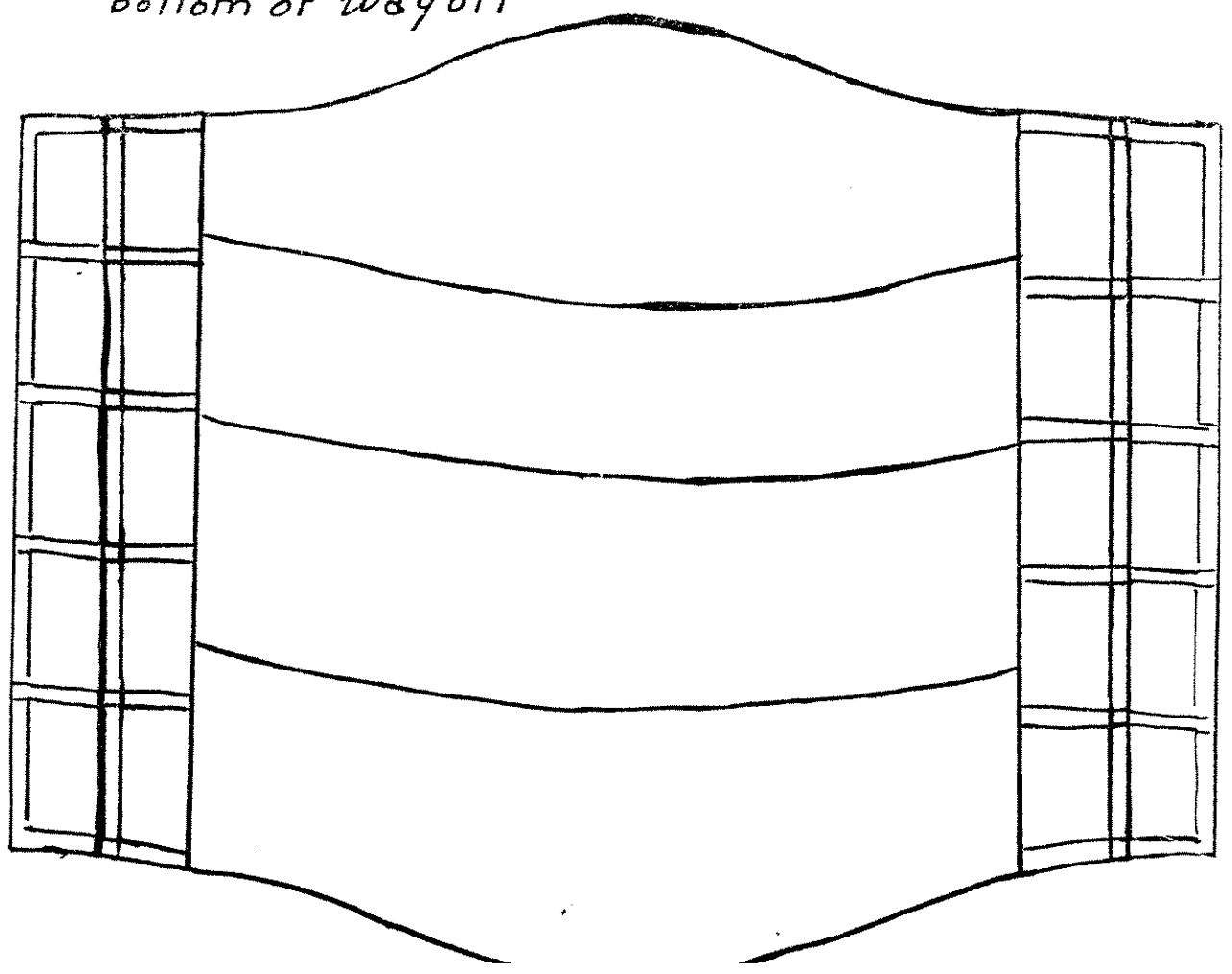

No. 27 Cannons

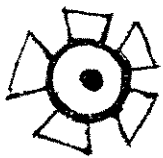
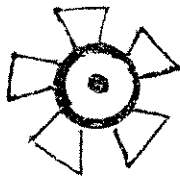
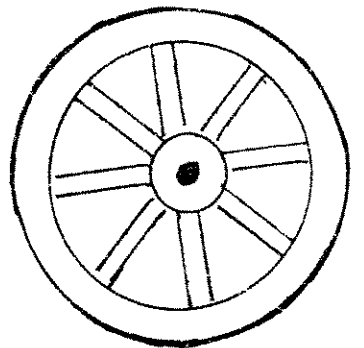
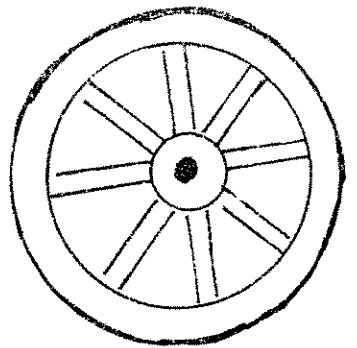
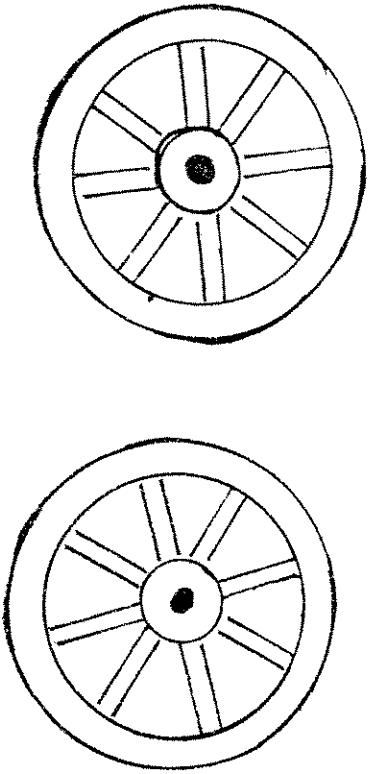
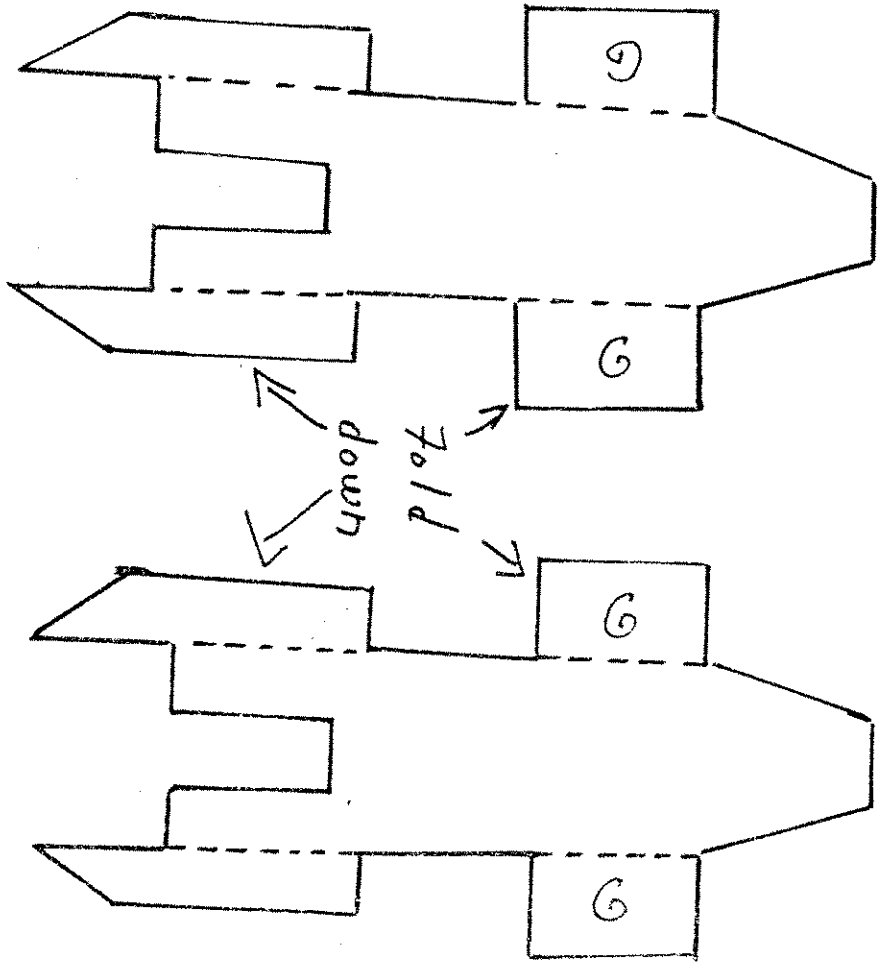

← end of
cannon

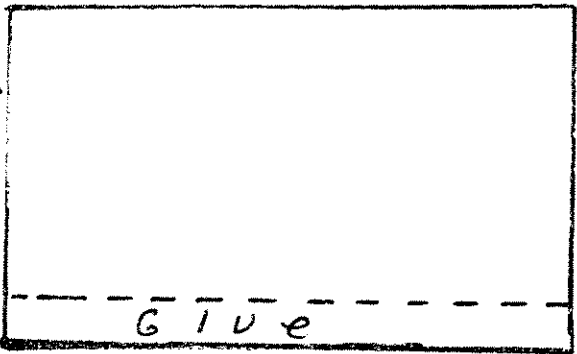
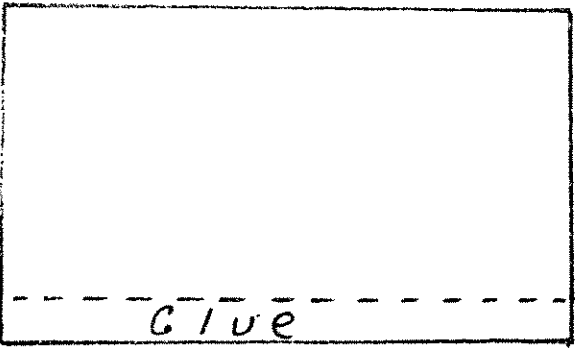

Roll on pen-cylinders

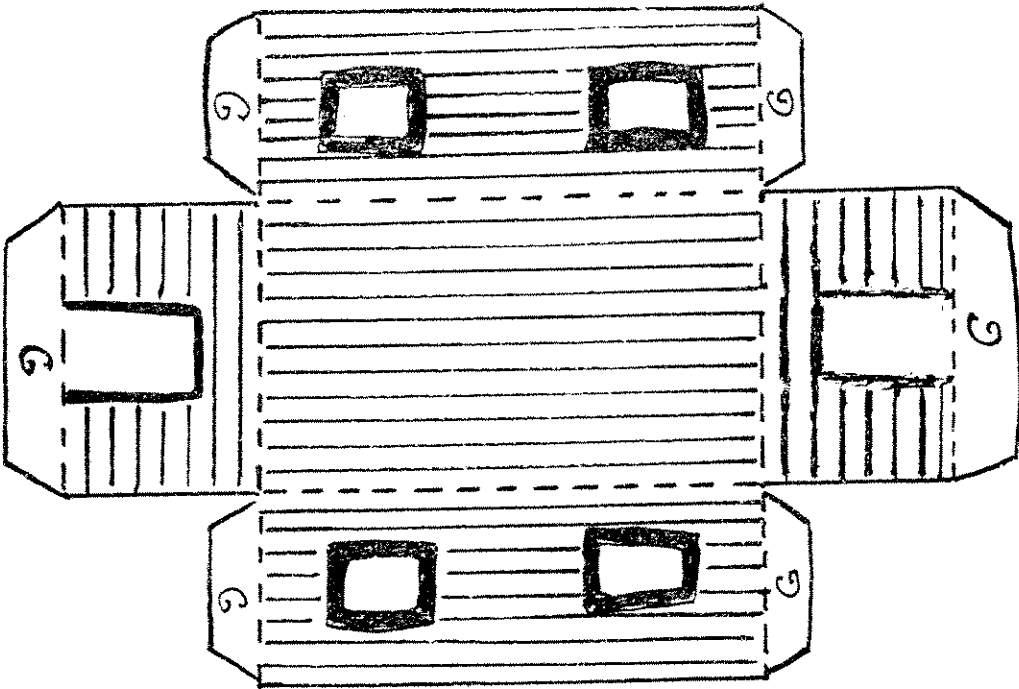
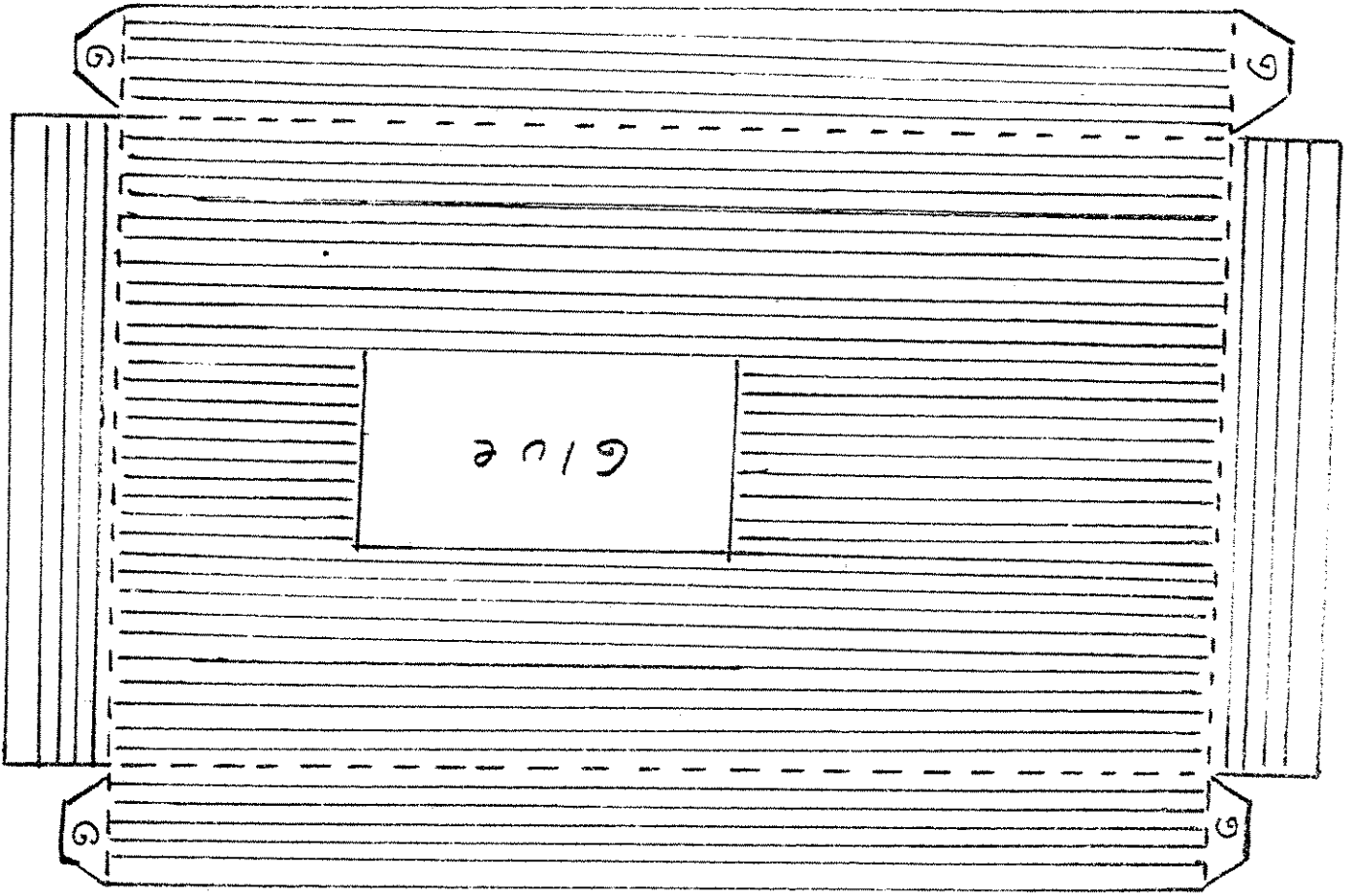

Fold down and
glue to boat

No. 12 Flatboat

40 Family Worship building

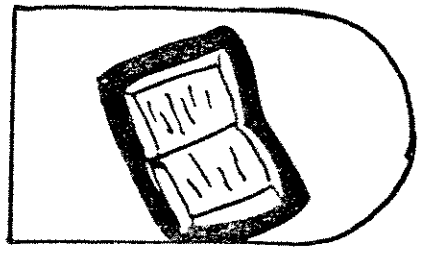
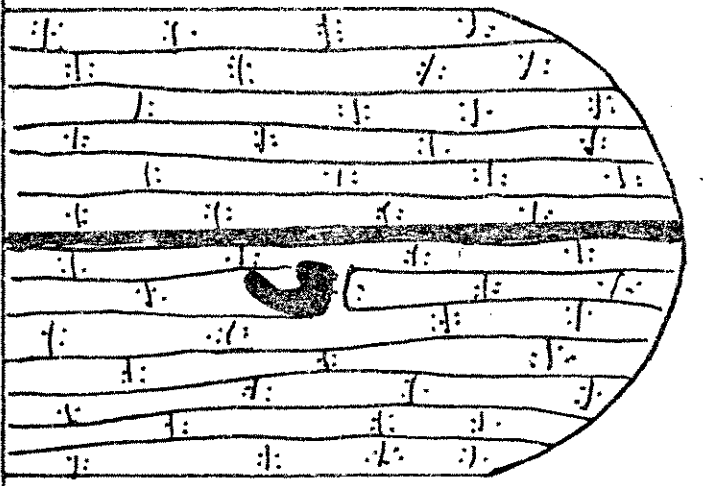
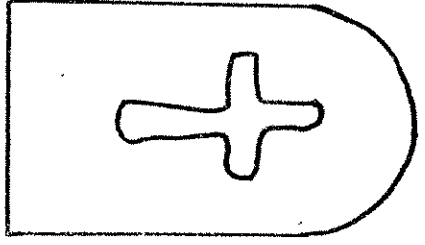
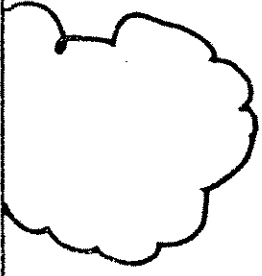
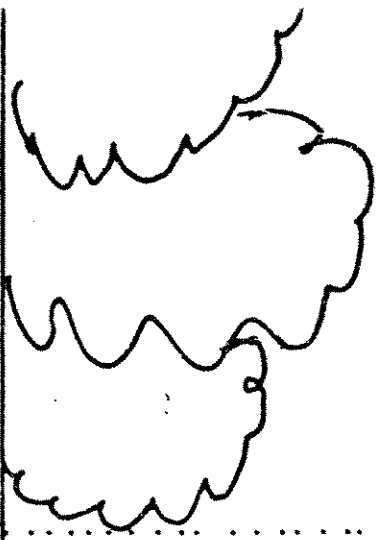

roof-
↓
glue to
steeple
↓
Glue

Glue

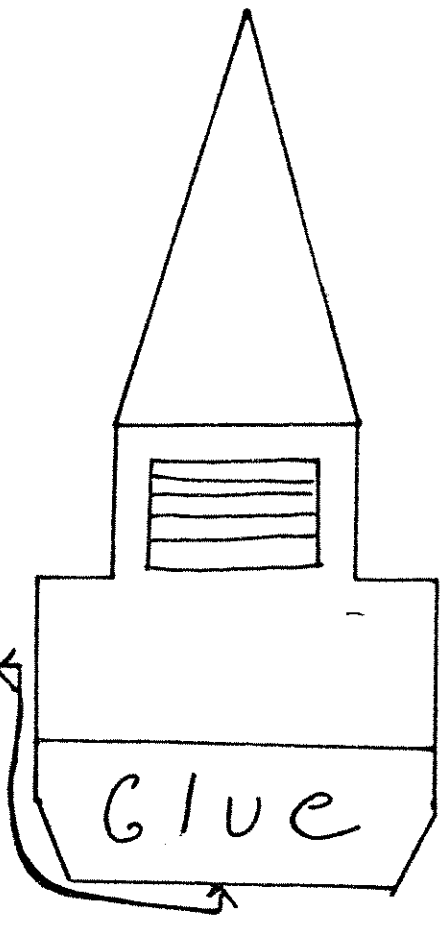

glue over
door
↓

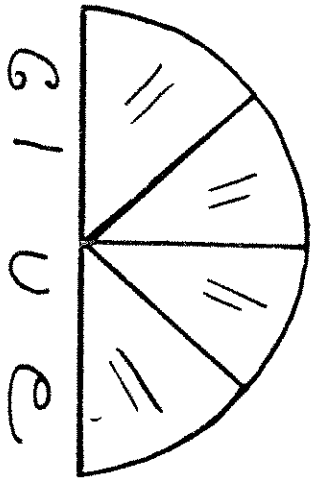

No. 11 woq Cabin

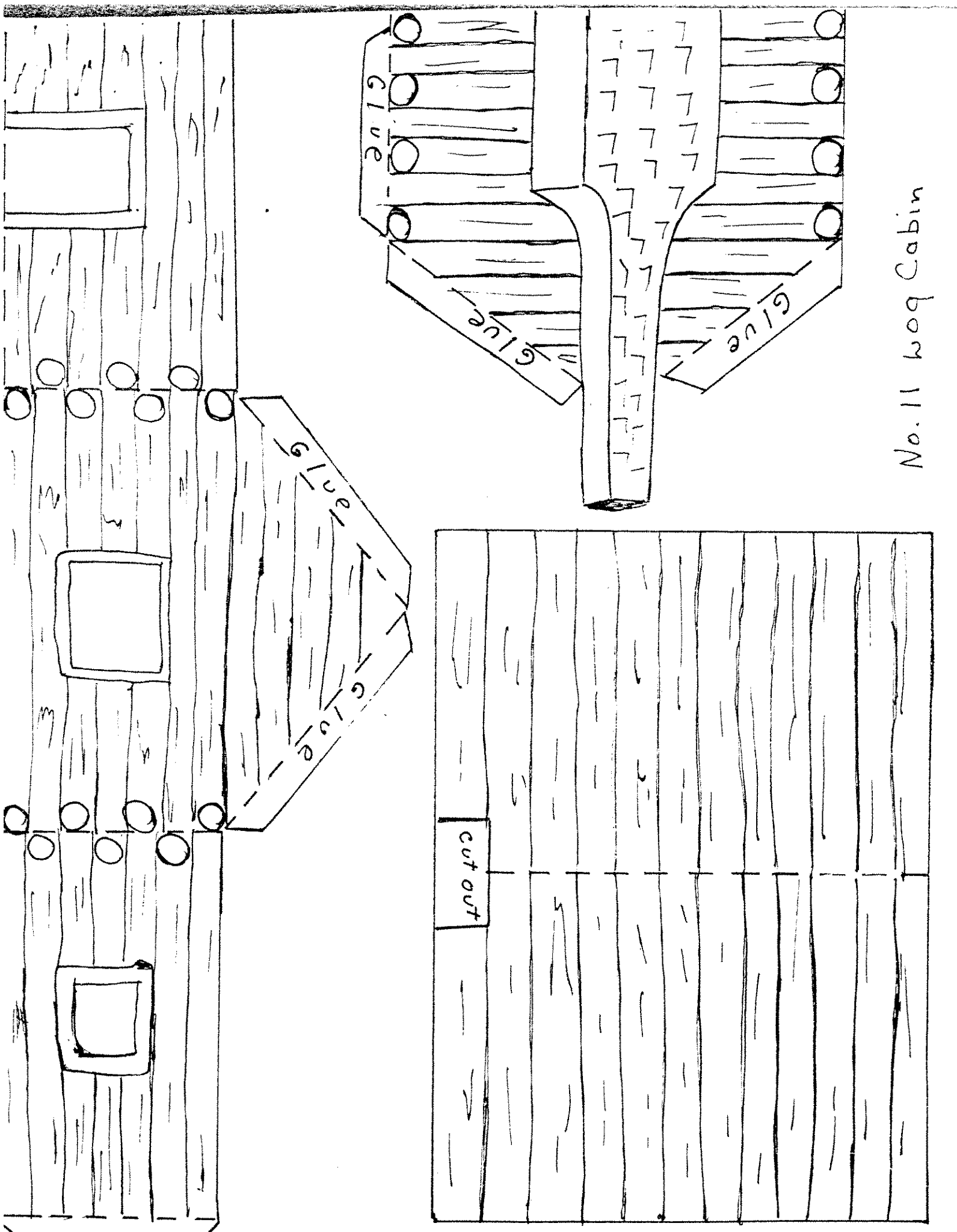

No. 24

Wagon
With
Slave

hay

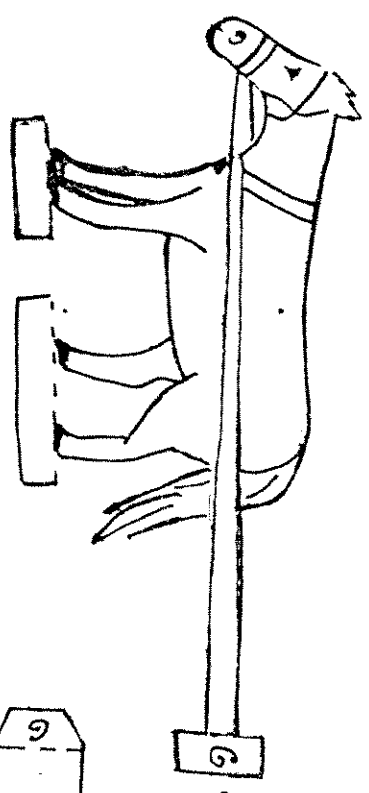
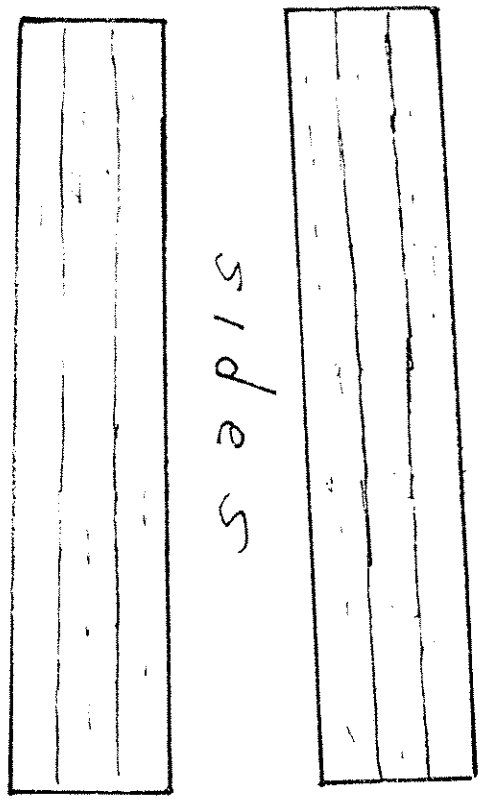
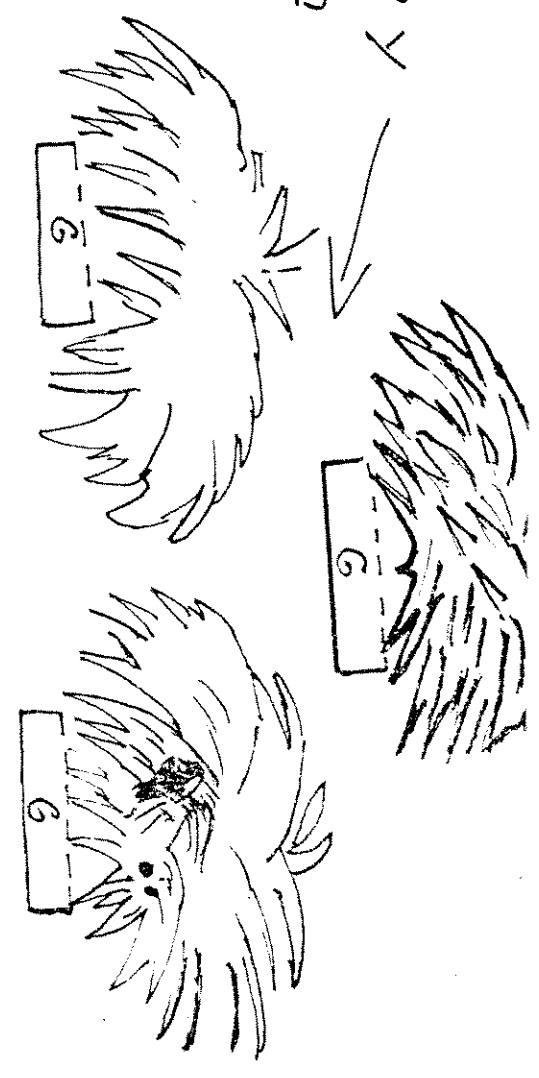

Front - Bottom

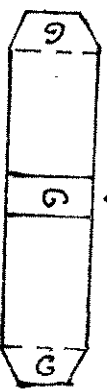

fold up

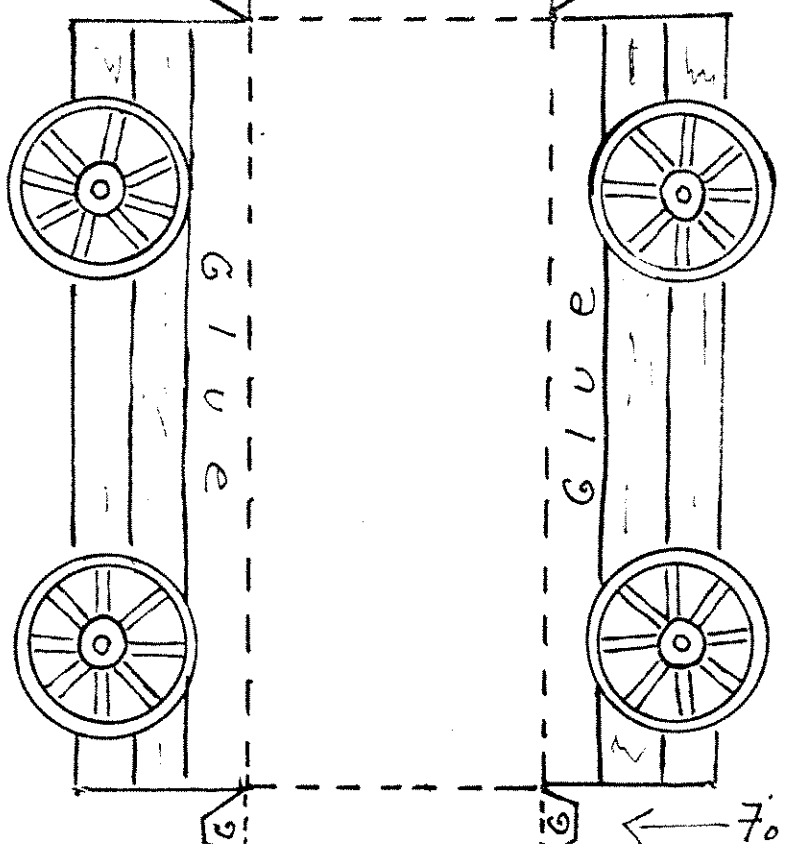
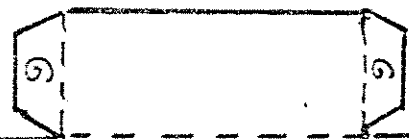

Back

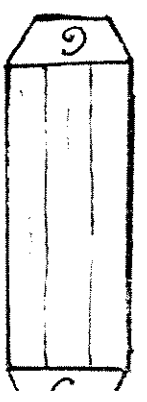

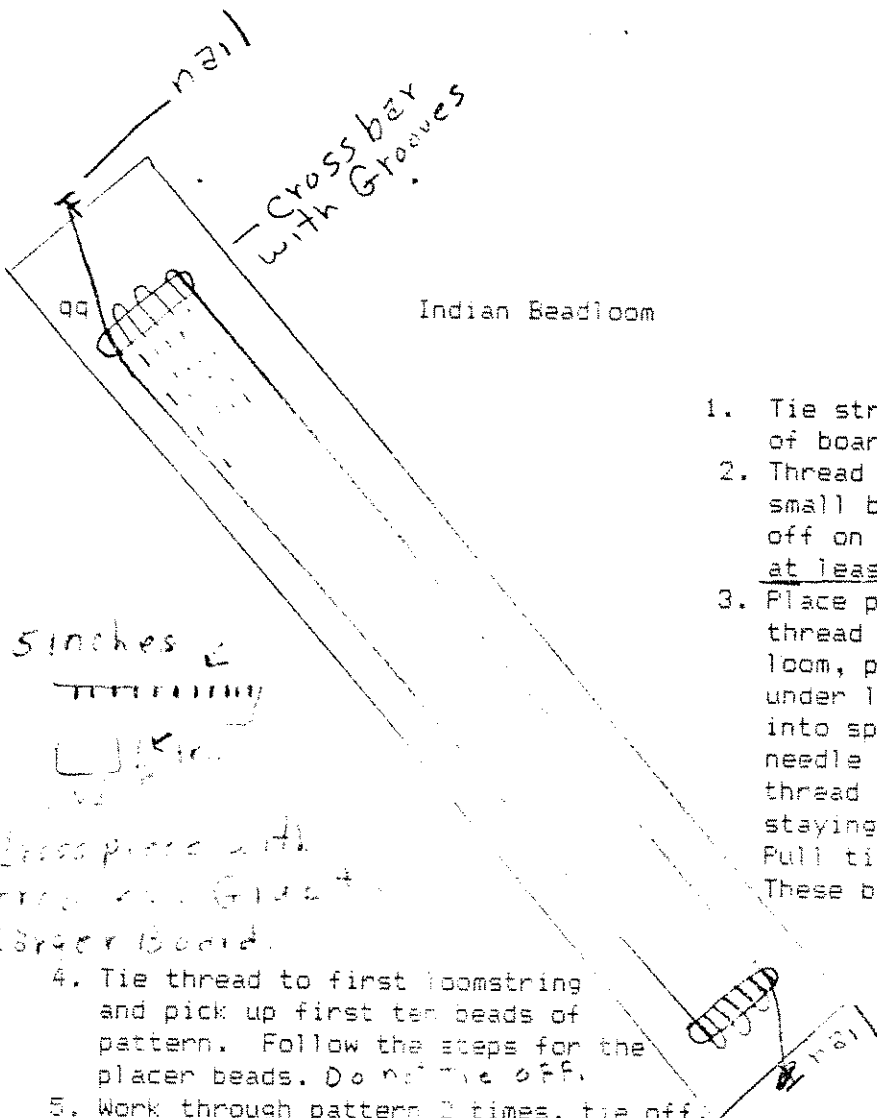

Indian Beadloom

1. Tie string to nail at one end of board.
2. Thread string through grooves in small boards (back and forth), tie off on nail at other end. You need at least 10 spaces.
3. Place spacer beads on strings (tie thread to loom string of left side of loom, pick up 10 beads, take needle under loomstrings and push beads up into spaces with fingers. Take needle over last loomstring and thread needle back through beads staying on top of all loomstrings. Pull tight and tie off. These beads act as spacers.

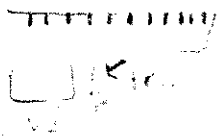
5 inches

2 pieces with Grooves + Larger Board.

4. Tie thread to first loomstring and pick up first ten beads of pattern. Follow the steps for the spacer beads. Do not tie off.
5. Work through pattern 2 times, tie off.
6. Cut loomstrings, leaving enough end strings to tape and fold under.
7. Tape ends of strings and fold under and sew to a piece of ribbon.
8. Ribbon bands can be secured with velcro.

my boards are 24 inches by 5 1/2 inches
 you need at least 11 Grooves to get 10 spaces.

